

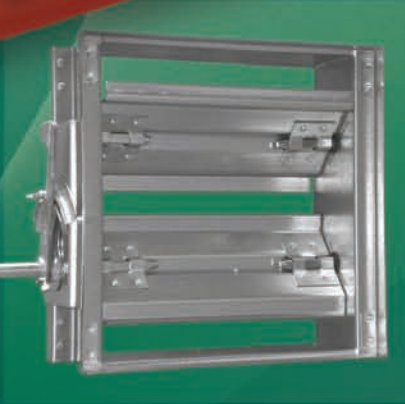

Air Damper Products



Standard 2 Day Shipping





ADP offers standard 2-Day “Quick Ship” service on all the products you see in this catalog at no increase in price for the premium service. For those occasions when even faster shipping is needed we also offer Next Day “Quicker Ship” and Same Day “Quickest Ship” options on most of our products, as follows:

Shipping Options	Lead Time (working days)	Percentage Add	Order Cut-Off Time
Quick Ship orders	2 Days Max	No Add	5:00 pm (Pacific)
Quicker Ship orders	Next Day	15%	5:00 pm (Pacific)
Quickest Ship orders	Same Day	25%	2:00 pm (Pacific)

Straight Talk: While our on-time shipping performance has exceeded 95% for five years running, it is possible that a sudden increase in demand or an unexpected large order could impact our stock, thus our *Quick Ship* options are subject to availability. Please see the Limitations paragraph below for your options, should a shortage occur.

Terms & Conditions

Lead Time: For standard 2-Day *Quick Ship* orders, the lead time clock begins the day after you place your order. For example, if you place your order on a Monday, the next day, Tuesday, is Day 1. You can expect your order to ship no later than Day 2, which would be Wednesday if there are no holidays. Orders entered after 5:00 pm are considered to be entered the next business day.

Quicker and *Quickest Ship* orders work similarly. For example, a Next Day *Quicker Ship* order placed on a Monday will ship the next day, Tuesday. Same Day *Quickest Ship* orders must be placed before 2:00 pm Pacific Time to be shipped the same day. Same day local delivery may also be available on orders placed by 10:00 am. Please call for availability.

Pricing: All prices are list. Please refer to your current Discount Schedule for applicable multipliers. 2-Day shipping is standard (subject to availability). For all orders under \$350 net, a Small Order Freight Add of \$30 will apply.

Freight Terms: All orders are shipped F.O.B. Origin. Actual freight rates will be charged for 2nd Day, Next Day, and Courier shipments, as well as on all orders that do not qualify for Prepaid freight. Please refer to your current Discount Schedule for Freight Factors on orders shipping 500 miles or more from the 92154 zip code.

Limitations: While our goal is to ship orders in two days or less, with our accelerated shipping schedule some shortages may occur. As a result, our *Quick Ship* options are subject to availability. Should we encounter a shortage on a qualified freight Prepaid order we will contact you to determine if you wish the entire order to be held until the shortages arrive (so everything ships prepaid) or if we should ship what we have available. Backorders cannot be shipped prepaid. Any items you instruct us to backorder will ship Prepaid & Add.

Payment terms: 1% 10, Net 30 from the date of our invoice for customers with approved credit. A service charge of 1.5% per month will be charged and collected on all past due account balances. Credit card payment is also accepted at time of purchase only, no discount allowed. Accounts with balances over 45 days old will be on shipping hold.

Returns: Returns will not be accepted unless accompanied by a Return Goods Authorization (RGA) form issued by ADP. Return goods will be inspected upon receipt by ADP and for all products accepted for restocking, 75% of the purchase price (excluding outbound freight) will be refunded. Products which have been installed or damaged (including packaging) are not suitable for restocking and no credit will be given. All returns must be returned to their point of origin, freight prepaid. If requested, we will issue a call tag for items to be returned, in which case return freight charges will be deducted from any credit issued.

Minimum order: For all orders under \$350 net a Small Order Freight Add will apply.

Changes: All orders are subject to a \$10 change fee per line item changed. Upon receipt of a change order, the date the change order is received becomes the new order receipt date and the lead time clock starts anew. Changes can not be accepted on the day of shipment.

Cancellations: Because of our accelerated shipping commitment we begin work on your order immediately upon receipt. Therefore, all orders cancelled after placement or before shipment will be subject to a 15% cancellation charge.

Damage or Loss: Unless otherwise agreed, all shipments are made F.O.B. Origin. ADP will not be responsible for delays in delivery by carrier, for loss or damage to merchandise in transit, for reconsignment fees or for storage fees due to delay in delivery. Where shortages or damages occur, details should be noted on the freight bill by the customer at time of delivery and reported to ADP within ten (10) days of shipment. In case of concealed damage, customer should call the carrier immediately to inspect damaged merchandise. With the exception of UPS and Fed-Ex ground shipments, all claims must be filed direct with the carrier by the customer. However, we will gladly assist our customer in attempting to secure prompt and satisfactory settlement.









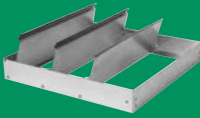

Warranty: ADP warrants our products for a period of twelve (12) months from the date of shipment against defects in materials and workmanship. If a product fails to perform properly within this period, ADP will replace or repair it at our option. This warranty does not extend to and does not cover defects caused by misuse, abuse, accident, improper installation or alteration. This warranty is for materials only and specifically excludes labor for removal or installation, as well as any and all forms of indemnification.

Force Majeure: ADP shall not be liable for delays or defaults in delivery caused by floods, fires, storms or other acts of God, by war or act of public enemy or civil disturbance, strikes, lockouts, shortages of labor or raw materials and suppliers (including fuel) or production facilities, transportation service or equipment shortages or failures, actions or any governmental authority, or other conditions beyond our reasonable control.

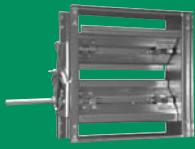
Sales: All sales are governed by the Terms and Conditions found on this page. If you do not accept these terms you must notify us within 24 hours of receiving our Acknowledgement. If you accept delivery of our goods, you will be deemed to have accepted these Terms of Sale in full. You further agree that these Terms of Sale supersede any additional or different terms or conditions contained in your purchase order or in any other agreement between you and ADP.

Air Distribution Products

9668 Heinrich Hertz Drive #D, San Diego, CA 92154 • Ph: (800) 322-8676 Fx: (800) 604-3324

	Brick Vents & Wall Louvers Pages 1-2		Bowden Cable Remote Balance Systems Page 8
	Square, Rectangular & Round Backdraft Dampers Pages 3-4		Battery Powered Remote Balance Systems Pages 9-10
	Square & Rectangular Control Dampers Page 5		Combination Fire/Smoke Dampers Pages 11-12
	Round Control Dampers Page 6		Curtain Blade Wall Fire Dampers Page 13
	Round Zone Dampers Page 7		Ceiling Radiation Dampers Pages 14-15

Features:

- Provides permanent means of ventilation for crawl spaces, hung ceilings, incinerator rooms, chimney flues, foundations, pipe spaces and corridors
- Mill finish extruded aluminum construction provides a high quality appearance
- Water stops and deep overlapping blades, each with integral storm drip provide maximum resistance to rain and weather
- Model BVE frame is 4" deep. Model BVF fame is 1-1/2" deep.



BVE Brick Vent

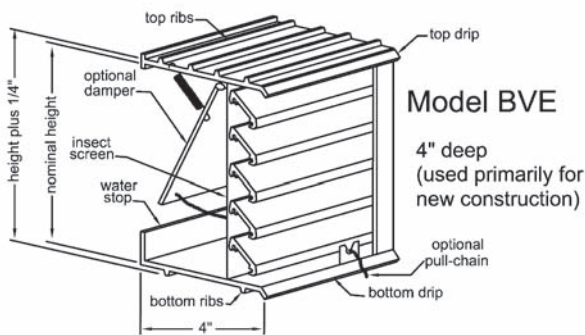

Model	Size	List Price	SKU
BVE 808	8.125" x 7.75"	150 •	41460
BVE 168	16.5" x 7.75"	200 •	41459

• White dots = Low demand items. Check availability before quoting.

Brick Vents

Model BVF

1-1/2" deep
1" face flange
(used primarily for renovation)

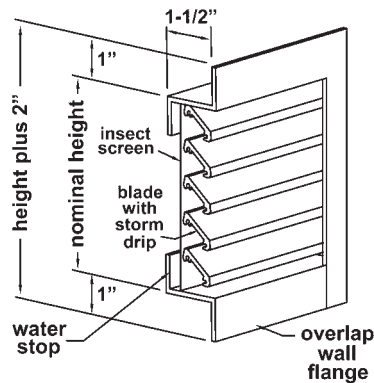

BVF Brick Vent

Model	Size	List Price	SKU
BVF 808	8.125" x 7.75"	150 •	41462
BVF 168	16.5" x 7.75"	200 •	41461

• White dots = Low demand items. Check availability before quoting.

DAL4 Features:

- Aluminum construction with fixed 4" blades
- Premium drainable blade design with downspouts in jamb
- AMCA Certified Performance
- May be used for exhaust or intake
- Includes rear mounted removable birdscreen
- Flange kits available for field attachment



DAL4 Louver

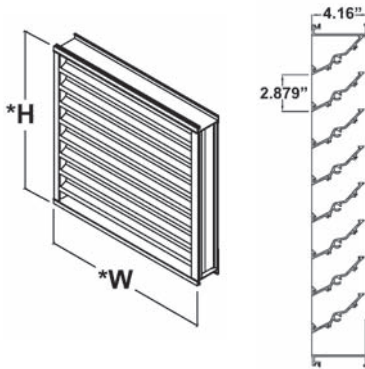

Size	DAL4 List Price	SKU	Flange Kit List Price	SKU
12" x 12"	203 •	41381	10 •	41439
18" x 18"	330 •	41382	17 •	41440
24" x 24"	415 •	41383	21 •	41441
30" x 30"	616 •	41384	32 •	41442
36" x 36"	730 •	413835	38 •	41443
48" x 48"	1115 •	41386	57 •	41444

Some rectangular sizes may also be stocked. Please call to check recent additions.

• White dots = Low demand items. Check availability before quoting.

Louver is undersized approx. 1/4"

Wall Louvers

GAFL Features:

- Innovative adjustable width flanged louver
- Expands horizontally to fit wall opening
- Galvanized steel construction
- May be used for exhaust or intake
- 1/2" bird screen kit included



GAFL Louver

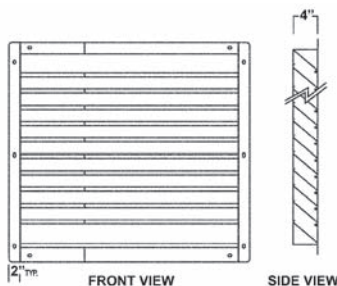

Size Adjustable width x height	GAFL List Price	SKU	Size Adjustable width x height	GAFL List Price	SKU
12" - 18" x 14"	201 •	44501	21" - 36" x 30"	469 •	44507
24" - 42" x 14"	469 •	44502	24" - 36" x 36"	551 •	44508
18" - 24" x 18"	291 •	44503	36" - 48" x 36"	756 •	44509
24" - 42" x 18"	517 •	44504	24" - 42" x 42"	894 •	44510
18" - 30" x 24"	335 •	44505	24" - 36" x 48"	817 •	44511
36" - 48" x 24"	568 •	44506	36" - 48" x 48"	945 •	44512

• White dots = Low demand items. Check availability before quoting.

Louver is undersized approx. 1/4"

Features:

- Galvanized steel frame
- Aluminum blades with edge seals
- Inter-connecting linkage
- Suitable for horizontal or vertical mounting (remove tension spring if installed vertically)



BDDS
Backdraft Damper

Size	List Price	SKU
08" x 08"	59	44101
09" x 09"	61	44102
10" x 10"	64	44103
11" x 11"	65	44104
12" x 12"	67	44105
14" x 14"	83	44106
16" x 16"	88	44107
18" x 18"	94	44108
20" x 20"	114	44109
22" x 22"	115 •	44110
23" x 23"	136 •	44126
24" x 24"	139	44111
28" x 28"	181	44112
30" x 30"	198	44113
34" x 34"	218 •	44114
36" x 36"	261 •	44115
40" x 40"	356 •	44116
42" x 42"	371 •	44117
44" x 44"	386 •	44118
46" x 46"	401 •	44119
48" x 48"	426 •	44120

White dots = Low demand items. Check availability before quoting.

Undersized approx. 1/4"

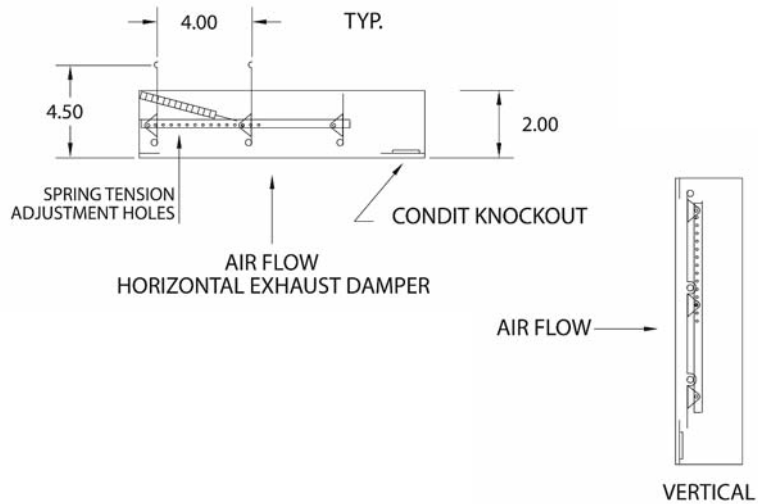

Optional Motor Kit

Features:

- 120/240 Volt
- Designed to fit Model BDDS dampers
- Simple attachment
- Handles dampers to 16 square feet in size

Model	List Price	SKU
BDDS MOTOR KIT	345	44125

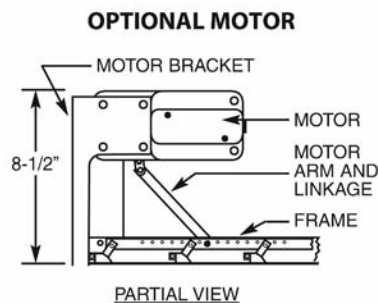

BDDS Motor Kit

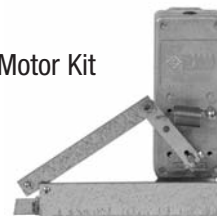

Backdraft Dampers – Flanged Type



Features:

- Aluminum construction
- 1-1/2" flanged frame
- Vinyl blade seals
- 2400 FPM maximum velocity
- Pressure to 3.5" WG
- Counter balance weight kits available for field attachment (call for price and selection)

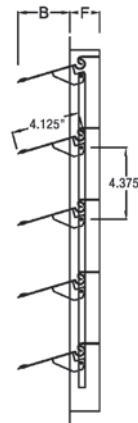

B = 3-3/4"
F = 1-3/4"



BDDF
Backdraft Damper

Size	List Price	SKU
8" x 8"	95 •	41393
10" x 10"	117	41394
12" x 12"	117	41395
14" x 14"	150	41396
16" x 16"	150 •	41397
18" x 18"	200	41398
20" x 20"	200 •	41399
24" x 24"	250	41400
30" x 30"	360 •	41401
36" x 36"	455 •	41402
48" x 48"	923 •	41403

• White dots = Low demand items. Check availability before quoting.

Undersized approx. 1/4"

Round Backdraft Dampers

Backdraft Dampers Butterfly Type

Features:

- 24 gauge galvanized steel
- 8" deep housing
- Aluminum spring-loaded butterfly damper
- Rubber gasket in closed position for minimum leakage
- Opens at .04 to .08 inches WG
- May be installed in any position



BDDR

Size	List Price	SKU
4"	57	41179
5"	60 •	41180
6"	63	41181
7"	85 •	41182
8"	98	41183
9"	100 •	41184
10"	118	41185
12"	174	41186
14"	296 •	41187
16"	349 •	41188
18"	386 •	41189

• White dots = Low demand items. Check availability before quoting.

Undersized approx. 1/8"

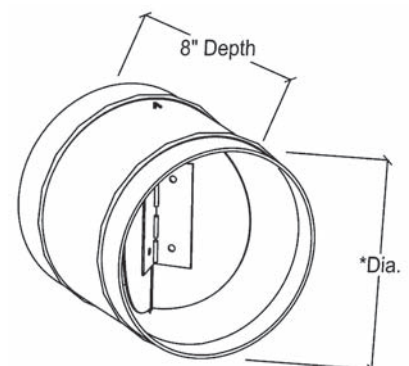

Control Dampers Opposed Blade Type

Features:

- Extruded aluminum construction
- Linkage concealed in frame
- Bronze oilite bearings
- Vinyl blade seals
- Stainless steel jamb seals
- Opposed blade action
- Optional 1/2" hand quadrant



CDOB



Size	List Price	SKU
6" x 6"	152	41334
8" x 8"	152	41335
10" x 10"	180	41336
12" x 12"	209	41337
16" x 16"	231 •	41338
18" x 18"	296	41339
24" x 12"	237 •	41420
24" x 24"	338	41340
30" x 30"	533 •	41341
36" x 36"	612 •	41342
48" x 48"	913 •	41343
Optional Hand Quadrant	25	43115

• White dots = Low demand items. Check availability before quoting.

Undersized approx. 1/4"

Manual Balancing Dampers Single Blade Type

Features:

- Aluminum construction
- Single blade design
- Pressures to 4" WG
- 2000 fpm maximum velocity
- Cast zinc 1/2" hand quadrant



BDSB

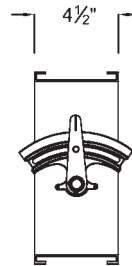

Size	List Price	SKU
6" x 6"	83	41328
6" x 8"	88	41329
8" x 6"	88	41330
8" x 8"	93	41331
8" x 10"	95 •	41421
10" x 10"	99	41332
12" x 12"	104	41333

Undersized approx. 1/4"

Manual Balancing Dampers Multi Blade Type

Features:

- Galvanized construction
- Opposed blade design
- Concealed linkage
- Pressures to 4" WG
- 2100 fpm maximum velocity
- Cast zinc 1/2" hand quadrant



BDMB

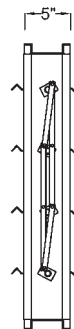

Size	List Price	SKU
12" x 12"	154	41344
16" x 16"	170	41345
18" x 18"	218	41346
20" x 20"	218 •	41347
24" x 24"	250	41348
30" x 30"	393 •	41349
36" x 36"	451 •	41350
42" x 42"	590 •	41351
48" x 48"	674 •	41352

• White dots = Low demand items. Check availability before quoting.

Undersized approx. 1/4"

Economy Balancing Dampers Disc Type

Features:

- Quality Construction
- Continuous Shaft
- Celcon Bearings
- Lockable Hand Quadrant
- Great Price!

Size	List Price	SKU
5"	73 •	41190
6"	73	41191
7"	76 •	41192
8"	82	41193
9"	88 •	41194
10"	94	41195
12"	100	41196
14"	108	41197
16"	114	41198
18"	120 •	41199

• White dots = Low demand items. Check availability before quoting.

Undersized approx. 1/8"



BDRB

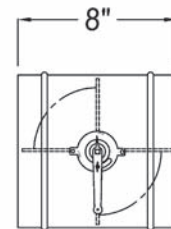

Manual Balancing Damper Kits

Features:

- Complete hardware included
- Lockable Hand Quadrant
- Easy installation
- Great Price!

Size	List Price	SKU
4"	8 •	71108
5"	9 •	71109
6"	9	71110
7"	10	71111
8"	11	71112
9"	12	71113
10"	12	71114
12"	18	71115
14"	18	71116
16"	18	71117
18"	20	71118
20"	23	71119

• White dots = Low demand items. Check availability before quoting.

Undersized approx. 1/8"



Disc Damper

Zone Dampers – Motorized Type

Features:

- Pressure applications to 2" w.g./2000 fpm
- Heavy gauge galvanized steel spiral shell, 8" length standard
- Heavy 18 gauge "V" style damper blade with 1/2" dia. steel shaft and oil impregnated bronze bearings
- Available in 3 configurations:
 - Round Balancing Damper (BCRD) (See page 8)
 - VAV Cooling only (RZD1)
 - VAV with Auto Changeover (RZD2)

Model RZD1 Pressure Dependent VAV, Cooling Only



Includes 3-wire, 24 volt stall-type reversing motor, 7 minutes from full open to full close and vice versa. Requires A400 floating control thermostat and T5401 24 volt transformer, both available separately.

Model RZD2 Pressure Dependent VAV with Auto-Changeover

Same as RZD2 above plus Auto Changeover relay and duct sensor module. Requires A400 floating control thermostat and T5401 24 volt transformer, both available separately.

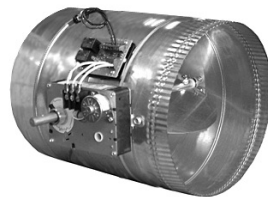

Damper Size	RZD1 List Price SKU	RZD2 List Price SKU
6"	339 Ask	587 Ask
7"	346 Ask	594 Ask
8"	346 Ask	594 Ask
9"	362 Ask	611 Ask
10"	362 Ask	611 Ask
12"	366 Ask	614 Ask
14"	413 Ask	661 Ask
16"	426 Ask	674 Ask
18"	473 Ask	721 Ask
Accessories		List Price SKU
T5401 40VA 120/24 volt Transformer		28 22244
A400 SPDT Center-off Thermostat		144 21808
ACRM Relay Mod		248 21809



A400



T5401



ACRM

Zone Dampers

ARD Features:

- 24 volt, Spring Return damper motor
- Power Closed/Spring Return standard. Can be field converted to Power Open/Spring Return
- Galvanized steel construction with single blade damper and gasketed stop
- Rated to operate up to 1" WC

SPRD Features:

- Single blade barometric damper for air bypass
- Counter balance weighted arm for bypass control
- Galvanized steel construction
- Recommended for low pressure systems

AUTOMATIC Round Damper (ARD)

ARD Size	List Price	SKU
6"	428	22284
8"	418	22138
10"	430	22139
12"	450	22140
14"	500	22141
16"	626	22285
18"	667	22286



ARD

STATIC PRESSURE Regulating Damper (SPRD)

SPRD Size	List Price	SKU
8"	271	22143
10"	300	22144
12"	340	22145
14"	333	22146



SPRD

Remote Cable Control Systems – Bowden Type

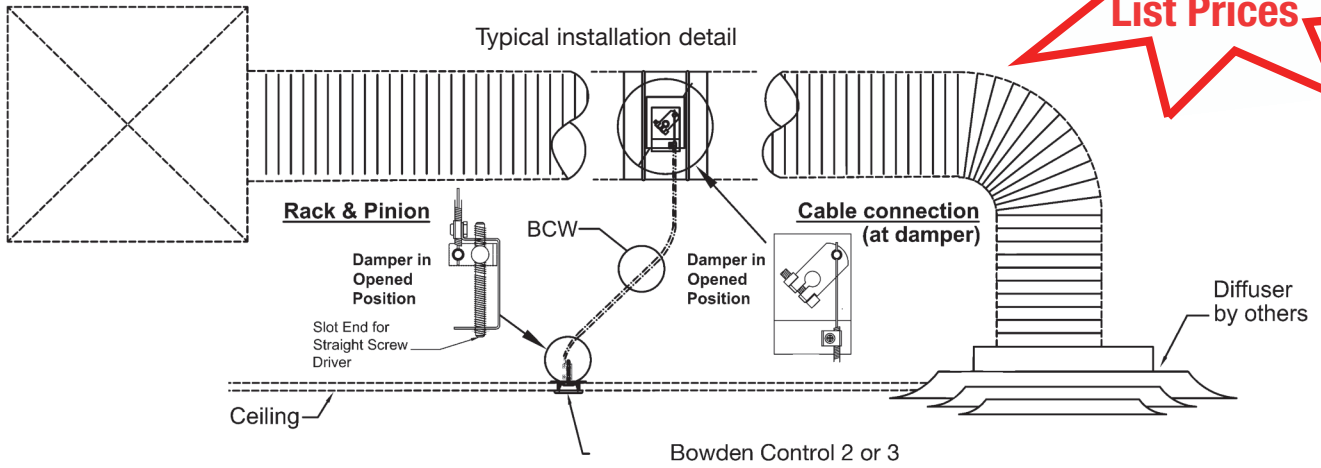

Bowden Controls		List Price	SKU
Control Kit BC1		78	41427
Control Kit BC2		108	41428
Control Kit BC3		96	41429
	BCW Cable and Wire (Price per ft.)	3	61603
	BCW Cable and Wire (50 ft. bundle)	129	61601

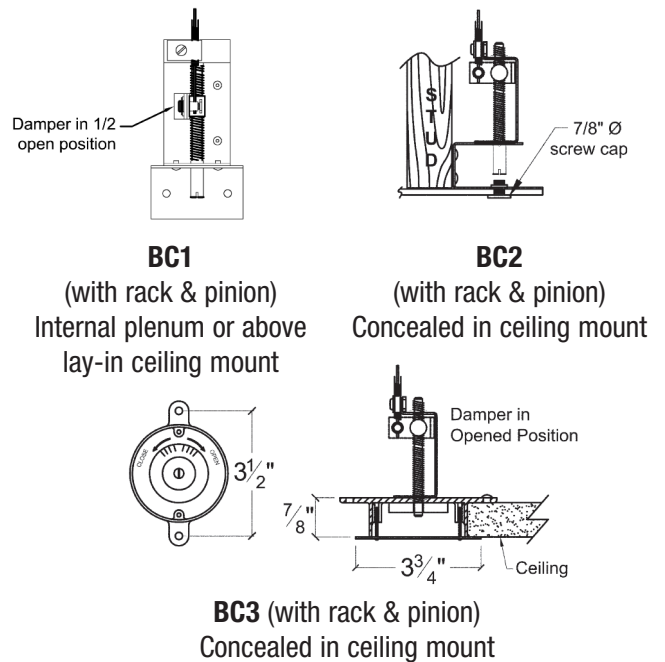

BCDR

BCDR Features:

- Single blade galvanized steel construction
- Raised bead on both ends for secure duct connection
- Includes double extended shaft for easy attachment of Bowden cable controls or a manual hand quadrant

BCDR Damper Size	List Price	SKU
6"	88	41430
7"	92	41431
8"	92	41432
9"	106	41433
10"	106	41434

BCDR Damper Size	List Price	SKU77
12"	108	41435
14"	144	41436
16"	154	41416
18"	188	41437
Hand Quadrant	25	43138

Precision Balance Systems

The model PB I3 PRECISION Balance System was developed for providing a means of balancing airflow in ductwork above inaccessible ceilings. Adjustments are accomplished by utilizing a hand-held powerpack.

Features:

- Sizes 6”-10”, frames and blades are 24 gauge galvanized steel
- Sizes 12”-18”, frames and blades are 20 gauge galvanized steel
- Synthetic nylon bearings
- 1/2” zinc plated steel axles
- Damper shell length 8” standard
- Custom sizes available

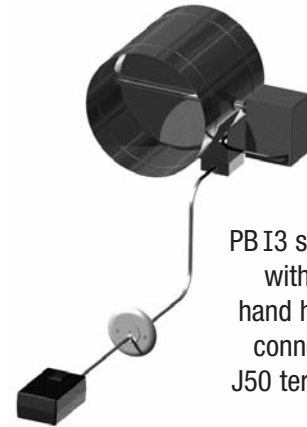

PB I3 shown above with optional hand held remote connected to a J50 terminal point.

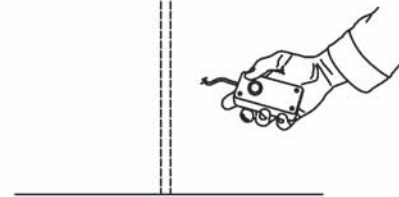
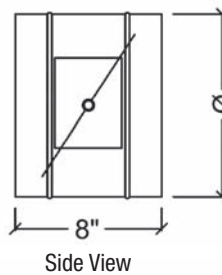
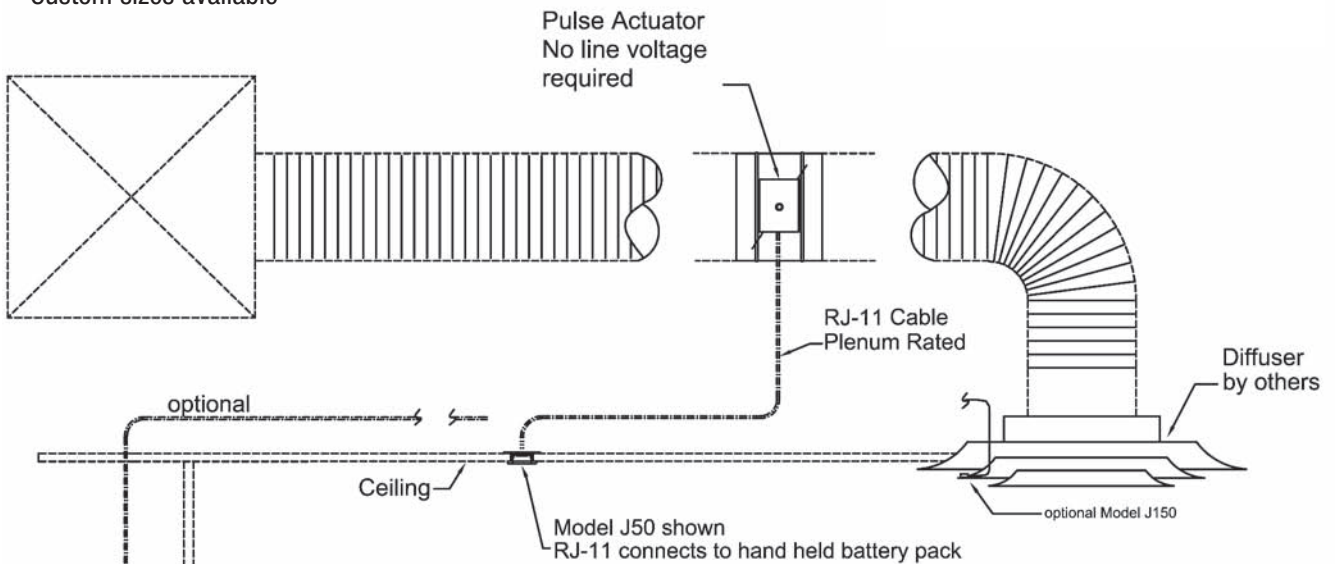

PB I3

Model	List Price	SKU
PB I3 06"	288	42100
PB I3 07"	296	42101
PB I3 08"	296	42102
PB I3 09"	296	42103
PB I3 10"	299	42104
PB I3 12"	316	42105
PB I3 14"	364	42106
PB I3 16"	410	42107
PB I3 18"	536	42108
Handheld Power/Balance Remote	170	42128

White dots = Low demand items. Check availability before quoting.

Precision Balance Systems – Installation Accessories

Model J50 (wall or ceiling terminal point)

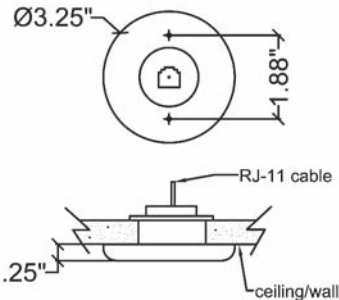

Model	List Price	SKU
PB J050 Term	23	42129

Model J100 (single gang wall terminal points)

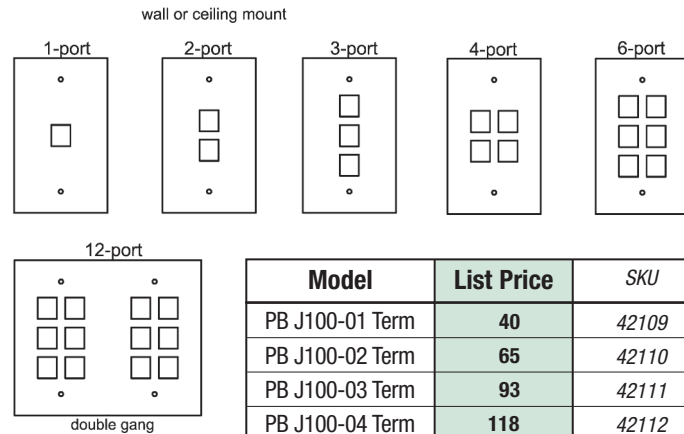

Model	List Price	SKU
PB J100-01 Term	40	42109
PB J100-02 Term	65	42110
PB J100-03 Term	93	42111
PB J100-04 Term	118	42112
PB J100-06 Term	181	42113
PB J100-12 Term	405	42114

White dots = Low demand items. Check availability before quoting.

Model J150 (diffuser terminal point)

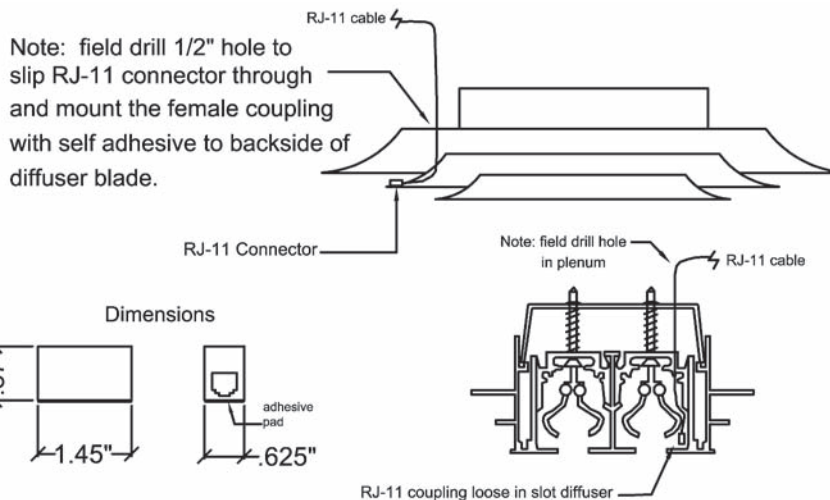

Model	List Price	SKU
PB J150 Term	8	42115

Model J300 (ceiling recess terminal point)

Polished zinc cover plate (standard)

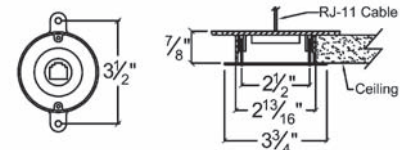

Model	List Price	SKU
PB J300 Term	101	42116

NPR: Power/Balance CAT5 Standard Cable
PR: Power/Balance CAT5 Plenum Rated Cable

Model	List Price	SKU
PB NPR Cable 05'	13	42117
PB NPR Cable 10'	20	42118
PB NPR Cable 25'	38	42119
PB NPR Cable 50'	84	42120
PB PR Cable 05'	29	42121
PB PR Cable 10'	58	42123
PB PR Cable 16'	101	42125
PB PR Cable 25'	152	42126
PB PR Cable 40'	240	42127
PB PR Cable 500'	188*	22263
RJ11 Connector	1	11321
Crimper 33 296	297	13271



PB NPR Cable



PB PR Cable

*No RJ11 connectors included

Fire/Smoke Dampers

(Dual Labeled For Wall & Corridor)



FS3VII Features:

- **UL555S** listed and labeled as a Class II Rated smoke damper with airflow in both directions
- **350°F** UL555S listed and labeled for 350°F
- **1½ hour** UL555 listed and labeled as a 1½ hour fire damper
- **Dual labeled** UL labeled for both wall and corridor applications up to size 24"x24"
- **Belimo** 120 VAC electric Belimo actuators, fail close
- **165°F** Thermal disc standard (212°F, 250°F & 350°F also available)
- **2000 FPM** Maximum velocity
- **4" WG** Maximum pressure

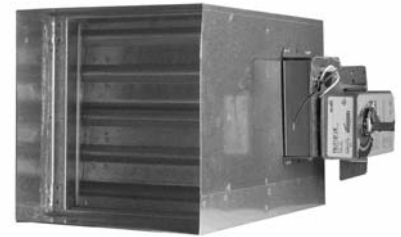

FS3VII

Construction:

- **Frame** Roll formed galvanized steel
- **Blades** 16 gauge, galvanized steel
- **Bearings** Bronze Oilite
- **Axles** Square, plated steel
- **Linkage** Concealed in frame
- **Finish** Mill galvanized
- **Sleeve** 16", 20 gauge galvanized steel (Maximum 6" wall thickness)

These models meet the requirements for fire dampers established by:

California State Fire Marshal
(Listing #3225-1722:107 for use in walls)

Underwriters Laboratories Standard 555

National Fire Protection Association
(NFPA Standards 90A)

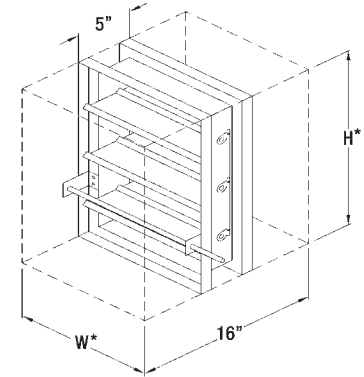

* Undersized approx. 1/4"

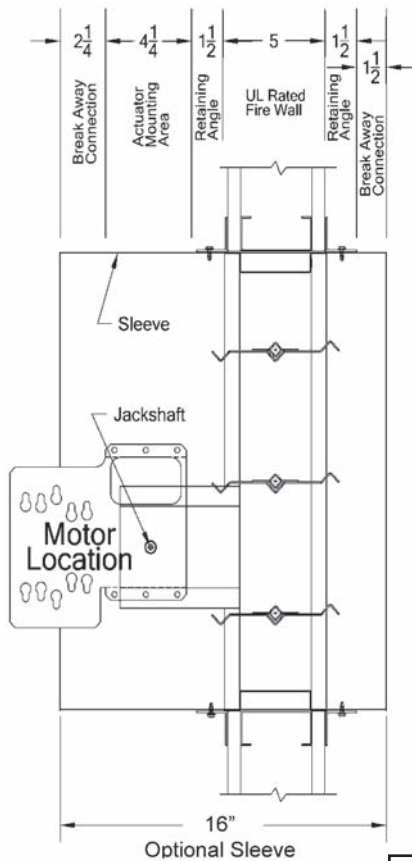

Retaining Angles	Add For Angles* (per stick)	SKU
6"	2	49112
8"	3	49114
10"	3	49116
12"	3	49118
14"	4	49120
16"	4	49122
18"	5	49124
20"	5	49126
22"	6	49128
24"	6	49130
26"	7	49132
28"	7	49134
30"	9	49136
32"	9	49138
36"	12	49140
42"	15	49142
48"	17	49144

Note: The standard actuator is externally installed on the lower right hand half of the damper when viewed from the jack shaft side. FS3VII has UL approval for the damper to be installed with the actuator on either the lower right hand side or rotated 180° so it is on the upper left hand side. The top of the damper could be either side of the frame, as long as the blades are running horizontal.

Note: Angles are priced per stick. For installations requiring angles on both sides of penetration, 8 sticks are required. For Angles on one side only, 4 sticks are required.

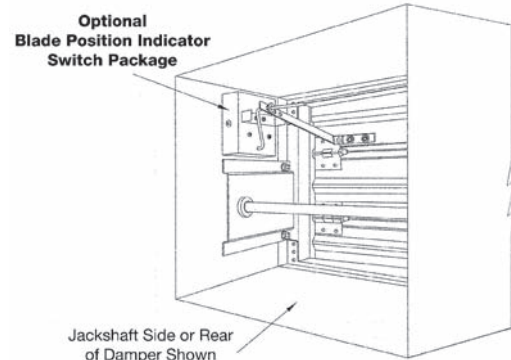

Model	Description	List Price	SKU
FS3 SWITCH PACKAGE	Optional blade position indicator switch package (loose)	116	41406
SPEC MOD 11	Add for mounting and wiring switch package	83	61615

Fire/Smoke Dampers



(Dual Labeled For Wall & Corridor)

Duct Size	List Price FS3V2	SKU	Duct Size	List Price FS3V2	SKU	Duct Size	List Price FS3V2	SKU	Duct Size	List Price FS3V2	SKU
6" x 6"	634	41100	20" x 8"	695	41123	26" x 14"	803	41148	32" x 20"	1015	41167
8" x 6"	634	41101	20" x 10"	724	41124	26" x 16"	844	41149	32" x 22"	1068	41312
8" x 8"	634	41102	20" x 12"	753	41125	26" x 18"	888	41150	32" x 24"	1068	41313
10" x 8"	653	41103	20" x 14"	806	41126	28" x 14"	844	41152	36" x 12"	855	41168
10" x 10"	679	41104	20" x 16"	806	41127	28" x 16"	844	41153	36" x 14"	905	41314
12" x 6"	653	41404	20" x 18"	854	41128	28" x 18"	888	41154	36" x 18"	1046	41169
12" x 8"	653	41105	20" x 20"	854	41129	28" x 24"	1023	41305	36" x 20"	1046	41315
12" x 10"	679	41106	22" x 6"	727	41304	28" x 28"	1095	41306	36" x 22"	1100	41316
12" x 12"	706	41107	22" x 8"	727	41130	30" x 6"	782	41307	36" x 24"	1100	41170
14" x 8"	684	41108	22" x 10"	750	41131	30" x 8"	782	41308	36" x 26"	1175	41317
14" x 10"	704	41109	22" x 12"	775	41132	30" x 10"	807	41156	36" x 36"	1508	41318
14" x 12"	729	41110	22" x 14"	823	41133	30" x 12"	830	41157	42" x 12"	1424*	41171
14" x 14"	782	41111	22" x 16"	823	41134	30" x 14"	878	41158	42" x 14"	1486*	41319
16" x 8"	684	41112	22" x 18"	871	41135	30" x 16"	878	41159	42" x 18"	1623*	41172
16" x 10"	708	41113	22" x 22"	908	41137	30" x 18"	924	41160	42" x 24"	1701*	41173
16" x 12"	730	41114	24" x 8"	727	41138	30" x 20"	1015	41161	42" x 42"	2568*	41320
16" x 14"	782	41115	24" x 10"	750	41139	30" x 24"	1068	41162	48" x 12"	1454*	41174
16" x 16"	782	41116	24" x 12"	775	41140	30" x 26"	1150	41309	48" x 14"	1531*	41321
18" x 8"	695	41117	24" x 14"	823	41141	30" x 30"	1228	41310	48" x 18"	1644*	41175
18" x 10"	724	41118	24" x 16"	823	41142	32" x 10"	807	41311	48" x 20"	1615*	41322
18" x 12"	753	41119	24" x 18"	871	41143	32" x 12"	830	41163	48" x 24"	1735*	41176
18" x 14"	806	41120	24" x 20"	871	41144	32" x 14"	878	41164	48" x 30"	2194*	41177
18" x 16"	806	41121	24" x 22"	908	41145	32" x 16"	924	41165	48" x 36"	2309*	41178
18" x 18"	854	41122	24" x 24"	908	41146	32" x 18"	924	41166	48" x 48"	2880*	41323

*Note: Larger sizes have two actuators wired to a single point connection.

Options, accessories and replacement parts

Model	Description	List Price	SKU
THERMAL DISC 212°	Optional 212° thermal disc (in lieu of standard 165°)	11	41298
THERMAL DISC 250°	Optional 250° thermal disc (in lieu of standard 165°)	11	41299
THERMAL DISC 350°	Optional 350° thermal disc (in lieu of standard 165°)	27	41300
FSFLANGE 8" LONG	Accessory 8" bottom flange for corridor applications, 8" long	3	41303
FSFLANGE SET 0808	Accessory 8" x 8" bottom flange for corridor applications	11	49341
FSFLANGE SET 1010	Accessory 10" x 10" bottom flange for corridor applications	14	49342
FSFLANGE SET 1212	Accessory 12" x 12" bottom flange for corridor applications	16	49343
FSFLANGE SET 1414	Accessory 14" x 14" bottom flange for corridor applications	19	49344
FSFLANGE SET 1616	Accessory 16" x 16" bottom flange for corridor applications	22	49345
FSFLANGE SET 1818	Accessory 18" x 18" bottom flange for corridor applications	25	49347
FSFLANGE SET 2222	Accessory 22" x 22" bottom flange for corridor applications	30	49347
FSLF-120-US	Replacement Belimo Actuator for dampers up to 4 sq. feet	614	12789
FSNF-120-US	Replacement Belimo Actuator for dampers up to 12 sq. feet	772	13310
SPEC MOD 11	Add for mounting one STR to Fire/Smoke damper	17	61522

White dots = Low demand items. Check availability before quoting.

Related items

Retaining Angles – Page 11

DWFD

Model DWFD is a Type A Dynamic Wall Fire Damper with an integral 12" sleeve. It is UL Classified for installation in walls, floors, and partitions with a fire rating of less than 3 hours. This damper may be installed vertically or horizontally in dynamic HVAC systems that continue to run in the event of fire. Also approved for static systems.



DWFD AXV12

Construction:

- **Frame** Roll formed, 20 gauge galvanized steel
- **Blades** Low-profile, roll formed, galvanized steel
- **Closure Springs** Stainless steel constant force coil
- **Maximum Velocity** 2000 FPM
- **Maximum Pressure** 4" WG
- **Fusible Link** Replaceable 165°F (212°F available)
- **Sleeve** 12", 20 gauge galvanized steel
- **Finish** Mill galvanized

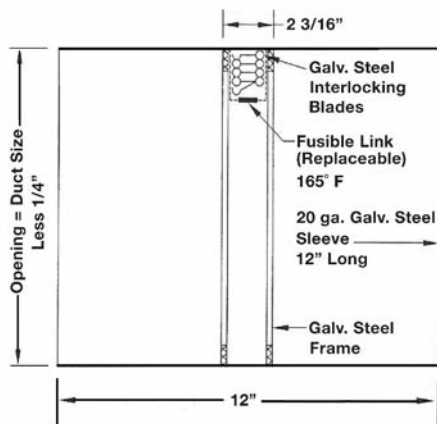

DWFD Fire Dampers	List Price	SKU
6" x 6"	88	49194
8" x 8"	94	49195
10" x 10"	104	49196
12" x 12"	107	49197
14" x 14"	142	49198
16" x 16"	142	49199
18" x 18"	172	49201
20" x 20"	172	49202
24" x 24"	199	49204
18" x 12"	138 •	49200
24" x 12"	148	49203

• White dots = Low demand items. Check availability before quoting.

These models meet the requirements for fire dampers established by:

- **California State Fire Marshal**
(Listing #3225-1722:100 for use in walls)
- **Underwriters Laboratories Standard 555**
- **National Fire Protection Association**
(NFPA Standards 90A, 80)

DWFD meets or complies with the following as a fire damper: All major building codes, including IBC/ICC International Code UL 555 Listing 1-1/2 Hour – File #R25410 ULC S112

Replacement Links	CRD Links List Price	SKU	DWFD Links List Price	SKU
165° Fusible Link	4 •	41301	4 •	41301
212° Fusible Link	4 •	41302	4 •	41302

• White dots = Low demand items. Check availability before quoting.

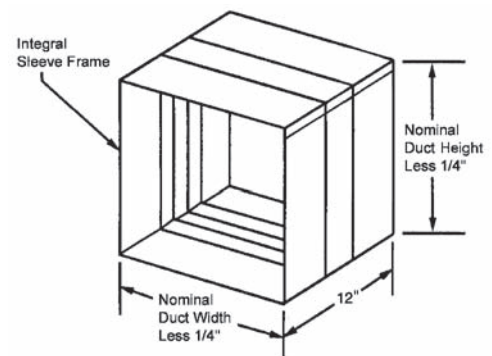

Related items

Flange Sets – Page 12

Square & Rectangular Ceiling Radiation Dampers



CRD

Model CRD is a square/rectangular UL Classified ceiling (radiation) damper, butterfly style, approved for both steel duct and ductless installations in approved UL ceiling designs that incorporate/show a hinged door damper requiring fire/heat protection where HVAC components penetrate the ceiling membrane. These dampers provide protection up to 22" x 22" openings.

CRD is stocked with top and bottom extended frame

Construction:

- **Frame** Roll formed - 22 gauge Galv. Steel
- **Blades** 22 gauge Galv. Steel with UL Classified Insulation on blades over 80 sq. inches
- **Spring** Corrosion resistant steel spring
- **Fusible Link** Replaceable 165°F
- **Finish** Mill galvanized



CRD

	CRD Radiation Dampers	List Price	SKU
NOT INSULATED	6" x 6"	61	49165
	8" x 8"	66	49166
INSULATED	9" x 9"	79 •	49167
	10" x 10"	79	49168
	12" x 12"	96	49169
	14" x 14"	107	49170
	15" x 15"	120 •	49171
	16" x 16"	120	49172
	18" x 18"	131	49173
	20" x 20"	155 •	49174
	22" x 22"	177	49176
	22" x 10"	120 •	49175

• White dots = Low demand items. Check availability before quoting.

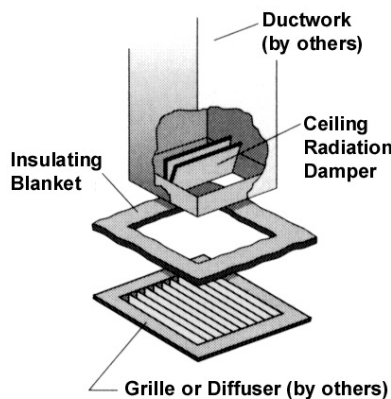

24" x 24" Thermal Blanket	List Price	SKU
	47	41293

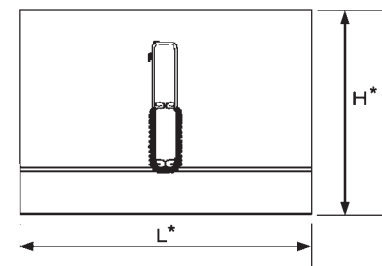

Extended Frame
*Undersized approx. 1/8"



Extended Frame Size (L)	Frame Height (H)
4" to 10"	6-3/8"
11" to 14"	8-3/16"
15" to 22"	11-3/16"

Related items

Flange Sets – Page 12

CRD-R

Model CRD-R is a round UL Classified ceiling (radiation) damper additionally approved for flex duct installations.

CRD-R is stocked without extensions

Construction:

- **Frame** 24 gauge Galv. Steel
- **Blades** 22 gauge Galv. Steel with U.L. classified insulation on blades over 10 inches
- **Spring** Corrosion resistant steel spring
- **Fusible Link** Replaceable 165°F
- **Finish** Mill galvanized

Listed and Labeled by:
California State Fire Marshal
 Listing No. 3226-1722:108



CRD-R

CRD-R Radiation Dampers	List Price	SKU
6"	57	49177
8"	63	49178
10"	67	49179
12"	83	49180
14"	93	49181
16"	115 •	49182

• White dots = Low demand items. Check availability before quoting.

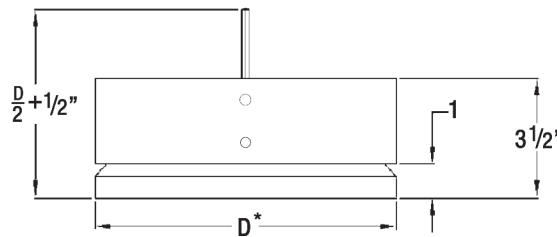

Standard Frame

* Undersized approx. 1/8"



- Same Day, Next Day and Standard 2-Day shipping options
- Next day delivery on orders placed as late as 5pm Eastern time
- The largest inventory of Fans, Dampers, and Air Distribution in the country
- Quality products with features and designs that save time and money
- Value by providing a premium service without the premium price



Air Distribution Products stocked		
Series	Description	Types/Sizes
APC	Perforated Diffusers – Curved Blade	191
APM	Perforated Diffusers – Modular	75
APA	Perforated Diffusers – Deflectors	12
APR	Perforated Returns	94
APX	Perforated Return Screens	7
AC	Cone Diffusers – Lay-in	16
AO	Architectural Plaque Diffusers – Lay-in	16
AL	Louvered Diffusers – Surface & Lay-in	20
AM	Modular Diffusers – Surface & Lay-in	27
CB	Curved Blade Diffusers – Surface	30
AR	Round Spun Diffusers – 2 & 3 Cone	18
ALS	Linear Slot Diffusers – 4 ft & 8 ft	32
ALSP	Plenums for Linear Slot Diffusers – 4 ft	20
AAB	Linear Air Bar Diffusers – 10 ft	14
AABP	Plenums for Linear Air Bar – 3 ft, 4 ft & 5 ft	23
DR	Drop Down Diffusers	8
DDV	Double Deflection Registers	129
FBH	Fixed Bar Return Grilles – Surface & Lay-in	244
FBHF1	Filter Return Grilles – Lay-in	7
EC	Egg Crate Return Grilles – Surface & Lay-in	20
ECF1	Egg Crate Filter Grille – Lay-in	6
HLF	Hard Lid Rapid Mount Ceiling Frames	6
OBDB	Opposed Blade Dampers – Black	60
BBD	Round Butterfly Dampers	14
SBD	Round Sliding Blade Dampers	5
STR	Square to Round Adapters – Black Interior	68
RTR	Round to Round Adapters – Black Interior	19

Air Device Products stocked		
Series	Description	Types/Sizes
SDT	Single Duct VAV Terminals	9
COIL	Hot Water Reheat Coils – 1 & 2 Row	14
ATTEN	Attenuators & End Caps	12
PNEU	Pneumatic Controls & Accessories	17
DIGI	Digital Controls & Accessories	14

Air Damper Products stocked		
Series	Description	Types/Sizes
FS3	Vertical F/S dampers, UL Class II, 350°	79
FS3	Corridor F/S dampers, UL Class II, 350°	28
DWD	Dynamic Curtain Type Fire Dampers	11
CRD	Ceiling Radiation Dampers	18
ANGLE	Retaining Angles & Flange Sets	24
RBDE	Round Balancing Damper, Electric Remote Powered	9
RBDEC	Hand Held Controllers, Terminals & Cable	18
RBDDB	Round Balancing Damper, Bowden	9
RBDDBC	Bowden Controllers & Cable	5
RBD	Round Balancing Damper with Quadrant	10
DISC	Disc Damper Kits	12
BDDR	Round Backdraft Dampers	8
BDDS	Backdraft Dampers – Steel	21
BDDA	Backdraft Dampers – Aluminum	11
CD1	Control Dampers – Aluminum	10
SB	Single Blade Economy Balancing Dampers	6
MD	Opposed Blade Balancing Dampers	9
BV	Brick Vents	4
DAL	Fixed Louvers, Drainable Blades & Jamb	6

Access Door Products stocked		
Series	Description	Types/Sizes
ADSM	Classic Sheet Metal Door, Hinged w/Cams	8
ADFR	1.5 HR Fire Rated Doors, UL & CSFM	3
ADMU	Multi-Use Doors, Hinged & Latched	8
ADLP	Low Pressure Spiral Duct Doors w/Latches	12
ADSD	Sandwich Type Spiral Duct Doors w/Knobs	9
ADSO	Oval Access Doors w/Cams & Chains	5
ADZL	Zero Leak Access Doors, Hinged w/Cams	16

Air Delivery Products stocked		
Series	Description	Types/Sizes
DCR	Roof Exhaust, Downblast Direct, UL705	21
BCR	Roof Exhaust, Downblast Belt, UL705	48
BCRU	Roof Exhaust, Upblast Belt, UL762	41
DSI	Inline, Direct Drive, Square, UL705	16
BSI	Inline, Belt Drive, Square, UL705	64
RSV	Round Spun Gravity Ventilators	12
CURB	Canted & Vented Roof Curbs	15
BDDS	Backdraft Dampers – Steel	21
BRO	Broan Ceiling & Cabinet Fans	16
BROI	Broan Inline Adapter Kits	14
JCS	Jacks, Caps & Switches	9
PANA	Panasonic Ceiling Fans	10
PANI	Panasonic Inline & Wall fans	5
CA/R	Round Inline Fans, Steel & Plastic	8
DQ	Dryer Vent Booster Fans – Cleanable	2
ISO	Vibration Isolation Mounts & Hangers	20

Air Duct Products stocked		
Series	Description	Types/Sizes
TFP	Poly Flex Duct	64
TFA	Aluma-Core Flex Duct, 6 ft CBE, Bare	32
SM	Galvanized Saddle Taps, T-Wyes & Elbows	58
SM	Galvanized Spiral Duct, KD Pipe & Caps	38
SM	Galvanized Tapers & Start Collars	33
SM	Galvanized Tee Tops w/Screen	6

Please visit our website for a complete list of products available

Ph 800.322.8676 • www.adp-hvac.com • Fx 800.604.3324

All this ships in **2 Days** or less! Who knew?

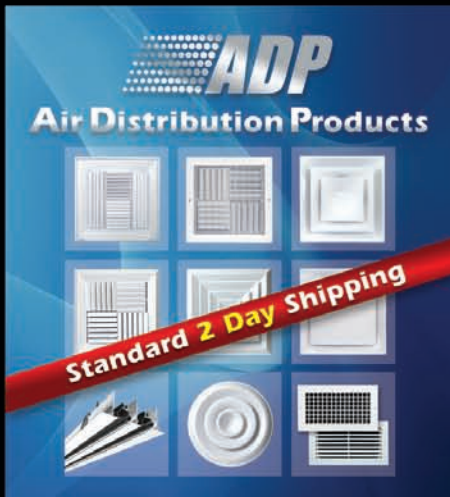

ADP
Air Distribution Products

Standard 2 Day Shipping

This banner features a blue background with a grid of nine images showing various air distribution products such as diffusers, registers, and grilles.



ADP
Air Device Products

Standard 2 Day Shipping

This banner features a yellow background with a grid of nine images showing various air device products including coils, filters, and control units.

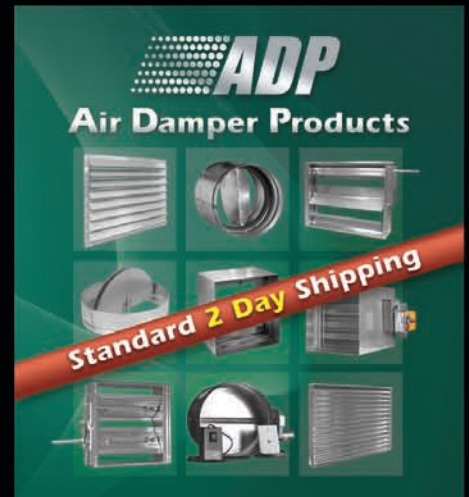

ADP
Air Damper Products

Standard 2 Day Shipping

This banner features a green background with a grid of nine images showing various air damper products such as dampers, valves, and actuators.



ADP
Air Delivery Products

Standard 2 Day Shipping

This banner features a yellow background with a grid of nine images showing various air delivery products including fans, blowers, and duct components.



ADP
Access Door Products

Standard 2 Day Shipping

This banner features a red background with a grid of nine images showing various access door products including doors, frames, and seals.



ADP
Air Duct Products

Standard 2 Day Shipping

This banner features a blue background with a grid of nine images showing various air duct products including elbows, tees, and straight sections.



Serving the HVAC Industry Since 1952

Ph 800.322.8676 • www.adp-hvac.com • Fx 800.604.3324

9668-D Heinrich Hertz Drive, San Diego, CA 92154